

# PWM and Tach Output Brushless DC Fan **06076EA-12S (0-Type)**

# NMB

## General Specifications

### Motor Type:

DC Brushless Three Phase Motor

### Motor Protection:

Auto Restart / Polarity Protection (Motor withstands reverse connection for positive and negative leads.)

### Insulation Resistance:

10MΩ or over with a DC 500V Megger

### Dielectric Withstand Voltage:

AC 700V 1sec or 500V 1min

### Allowable Ambient Temperature Range:

-10°C ~ + 60°C (Operating)

-40°C ~ + 70°C (Storage)

(non-condensing environment)



*\*For reference only. Please refer to fan outline for details*

## Characteristic Curves

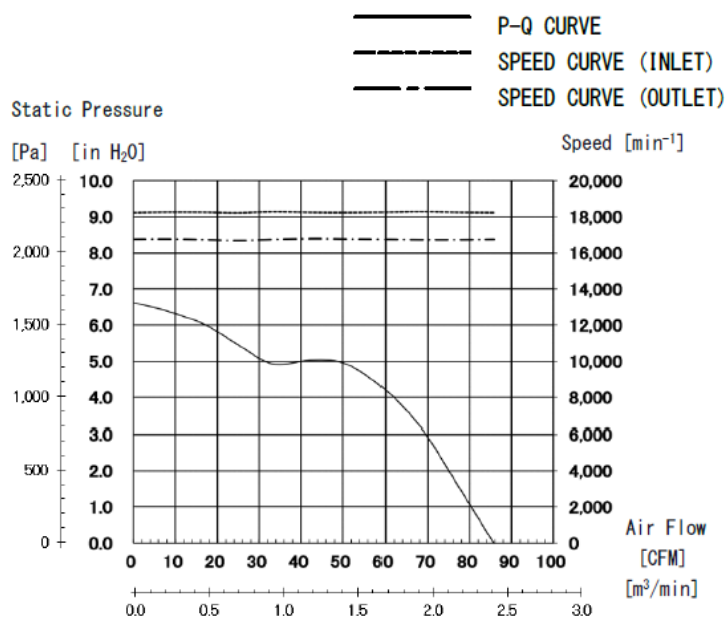

## Features

- High performance counter rotating fan with eight wires and PWM with tach signal
- Efficient motor technology, high torque, and aerodynamic impeller design
- Energy saving, low vibration, and increased life expectancy
- Available in 12 volts with tach output and PWM speed control
- Outfitted with NMB precision machined ball bearings for long life

## Life Expectancy L10

70,000 Hours at 40°C

*\*Fan life expectation is based on free air operation at 40°C, rated voltage, and indoor benign lab environment*

*\*1: Values in Free Air*

## Specifications

MODEL	Rating Voltage (V)	Operating Voltage (V)	Current		Input Power		Speed Inlet/Outlet (min <sup>-1</sup> )*1	Max. Air Flow		Max. Static Pressure		Noise (dB)*1	Mass (g)
			Avg (A)*1	Max (A)*1	Avg (W)*1	Max (W)*1		(CFM)	(m <sup>3</sup> /min)	(in H <sub>2</sub> O)	(Pa)		
06076EA-12S-E6-0C	12	10.8 to 13.2	4.55	5.60	54.6	67.2	18,200/16,700	85.7	2.40	6.62	1650	78.0	245

# PWM and Tach Output Brushless DC Fan 06076EA-12S (0-Type)

NMB

## PWM Specifications

### Connection

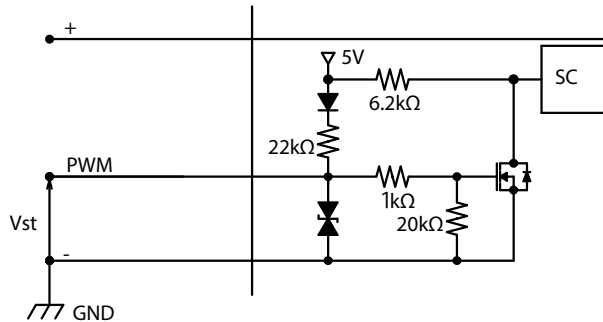

### 1. PWM Control

- $V_{st} = \text{Low Level (0V} \sim \text{0.4V)}$  → Stop (On Duty 0%)
- $V_{st} = \text{High Level (3.0V} \sim \text{5.0V)}$  → Full Speed (On Duty 100%)
- $V_{st} = \text{Open}$  → Full Speed

### 2. PWM Duty & PWM Input Pulse

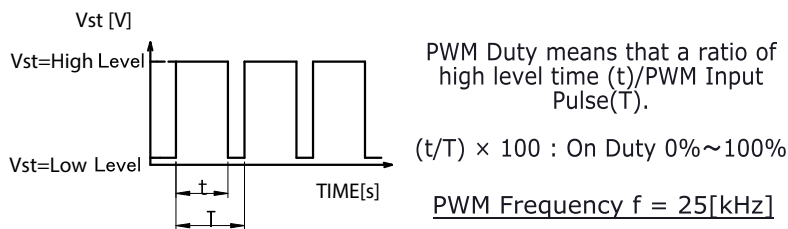

### 3. The condition for PWM control are as follows

- When you use this under PWM control, always be sure the motor's operation under practical mounting state. Fan motor may not start up caused by PWM control at very low speed condition.)
- To run at Rating Voltage
- Please use the start with Duty 20% or more at 25kHz.[At rated voltage input, Ambient temperature 25°C]

## PWM Characteristic Curve

### INLET SIDE

PWM Duty vs Speed Curve  
<Reference Value>  
Conditions: At Rating Voltage,  
 $V_{st}=3.3V$ ,  $f=25kHz$ ,  $T_a=25^\circ C$

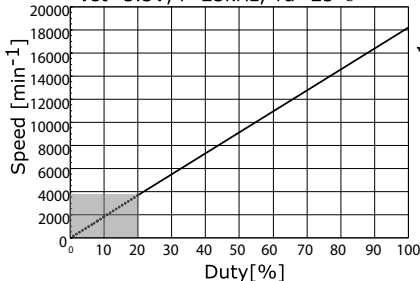

### OUTLET SIDE

PWM Duty vs Speed Curve  
<Reference Value>  
Conditions: At Rating Voltage,  
 $V_{st}=3.3V$ ,  $f=25kHz$ ,  $T_a=25^\circ C$

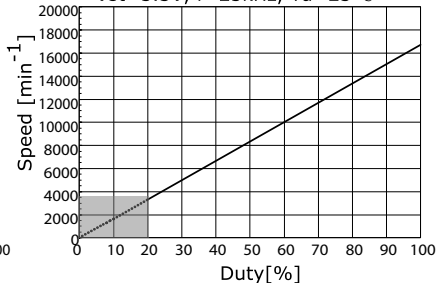

## TACHO Specifications

### Tachometer Signal

1. OUTPUT CIRCUIT : OPEN COLLECTOR
2. SPECIFICATION  
Absolute Maximum Ratings at  $T_a=25^\circ C$   
 $V_{CE \text{ max}} : +15V$   
 $I_c \text{ max} : 5mA$  [ $V_{CE(sat)max} = 1.5V$ ]

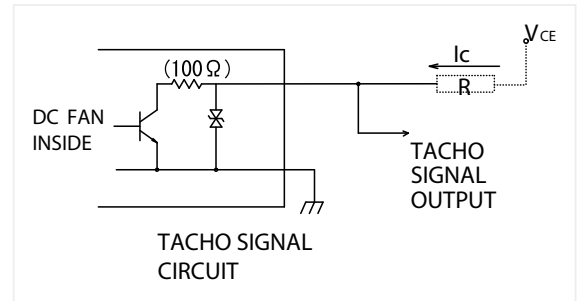

### 3. Output Waveform: At Rated Voltage Output Signal Voltage

#### Case-1

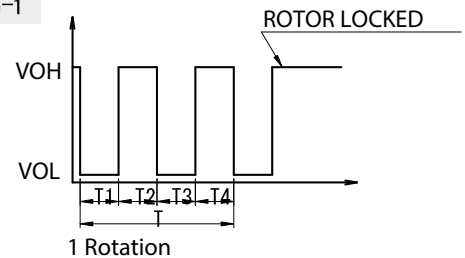

#### Case-2

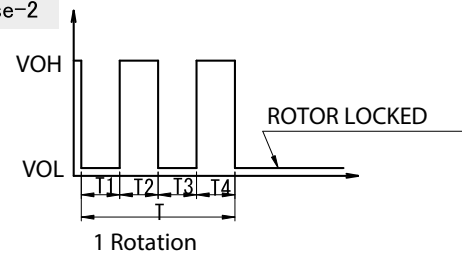

- 1) When the rotor is locked at VOH position of signal, signal keeps VOH position.
- 2) When the rotor is locked at VOL position of signal, signal keeps VOL position.
- 3)  $T=T_1+T_2+T_3+T_4=60/m=1 \text{ rotation}$

$m$ : Fan Speed ( $\text{min}^{-1}$ )

Tacho Duty Cycle=50%±10%

# PWM and Tach Output Brushless DC Fan 06076EA-12S (0-Type)

# NMB

## Outlines

(Name Plate)

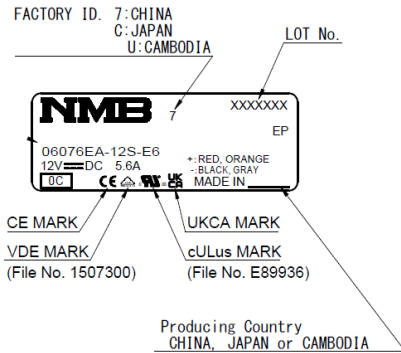

## Materials

**Casing [Inlet & Outlet]:** Plastic(Black UL94V-0)  
**Impeller [Inlet & Outlet]:** Plastic(Black UL94V-0)  
**Bearing:** Steel Ball Bearing  
**Lead Wire:** UL10368 AWG22 for Red, Black Orange, Gray or Equivalent  
 UL10368 AWG24 for White, Brown, Yellow, Blue or Equivalent  
**[Inlet Fan]:** Red (+), Black (-), White (Tach), Brown (PWM)  
**[Outlet Fan]:** Orange (+), Gray (-), Yellow (Tach), Blue (PWM)

(Outline)

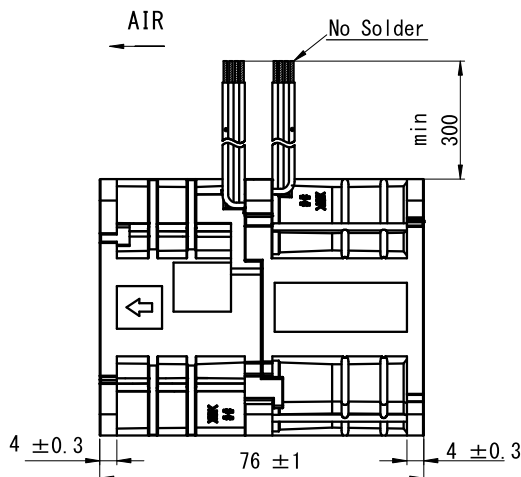
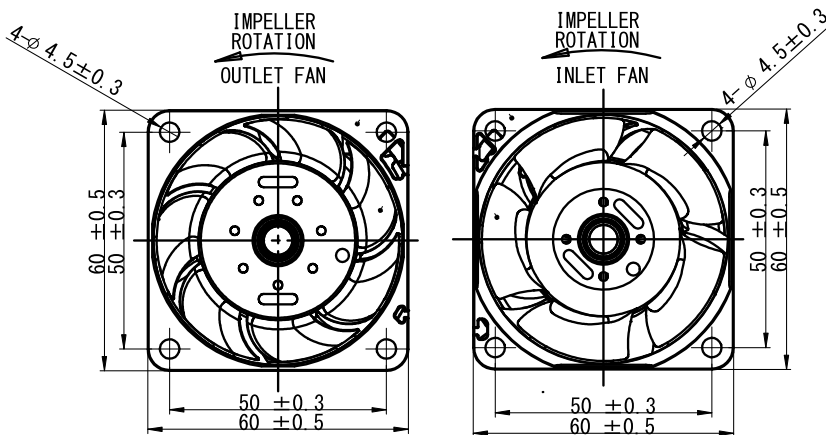

(Panel Out-line)

